

Safety, Warnings and Suggestions

- ¹ *Care* should be taken not to position fixtures in locations where bare skin can come into contact with the potentially high temperatures on the lens.
- ² *Avoid* installing fixtures in locations where water collects and stands for prolonged periods.
- ³ *Make* sure that electrical power is disconnected before any work is performed.
- ⁴ *All* gaskets and sealing surfaces must be kept clean during installation.
- ⁵ *As* a rule of thumb, the higher the fixture is mounted above grade potential problems such as foliage over growth or water, mud etc. collecting on the lens are reduced.
- ⁶ *All* wiring and installation should meet local, state and national electrical codes.
- ⁷ *This* will help prevent wire connector corrosion due to water penetration from the conduit.
- ⁸ *Install* correct lamp type and wattage.
- ⁹ *If* condensation, built up during installation, is visible on the lens it is recommended that the fixture be turned on before the lens ring is fully secured for approximately 30 minutes. This should allow the condensation to be exhausted.

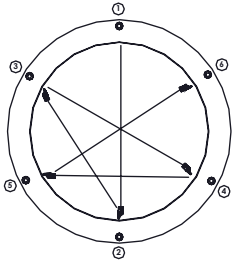

Use several rotations of the following sequence to firmly tighten the lens ring screws, to 25 in/lbs.

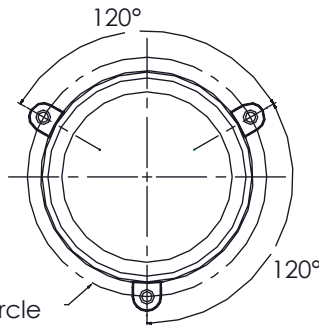

Bolt Circle
Dia. 10.25"

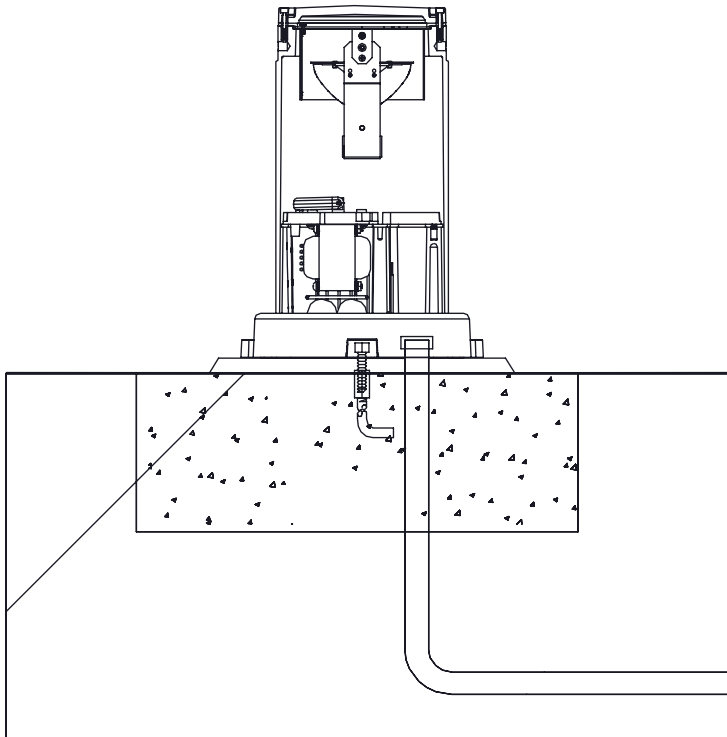

1. Prepare the site with adequate excavation and install the anchor bolts and 3/8" couplers per factory supplied template ¹.
2. Remove lens ring and lens with gasket, ⁴ reflector assembly and "D" shaped splice box cover plate.
3. Connect conduit to the 3/4" NPT openings in the splice compartment at the bottom of the fixture, using the appropriate thread sealing compound. Tighten to 15 ft-lbs. max.
4. Make power and ground connections using the water-proof connectors provided. It is recommended that RTV Silicone or other re-enterable water sealing compound be used to seal the conduit entry points ⁷.
5. Reinstall "D" shaped splice box cover plate ensuring that all three (3) screws are securely tightened. ⁴ Reinstall reflector assembly, install lamps and make aiming adjustments.
6. Install lens ring and lens with gasket ⁴ **IMPORTANT! A CRISS CROSS PATTERN IS REQUIRED TO ENSURE THAT A GOOD COMPRESSION SEAL IS MADE.** If this is not accomplished the fixture could leak and be damaged. Tighten screws gradually using multiple tightening steps to 25 in/lbs.
7. Install three bolts and level. Secure the base with (3)-3/8 socket cap or Allen cap bolts.