

SUPPLEMENTAL INSTRUCTIONS, SL-29LED-RGB

1. Remove lens ring, lens, and gasket.
2. Loosen screws ①, eight places, see figure 1.
3. Remove screws ②, eight places.
4. Remove shipping restraints ③ and ④. Keep these parts in case fixture has to be shipped back to the factory.
5. Carefully lift LED cluster ⑤ by grasping center heatsink ⑥. Rotate LED cluster slightly and place on top of housing, see figure 2.
6. Disconnect cables ⑦. Warning: Do not unplug wires at the LEDs.
7. Remove LED cluster and place on a clean flat surface with the LEDs facing up.
8. Rotate LED cluster 90 degrees so it is lying on its side, see figure 3. Warning: do not place LED cluster upside down on the LED lenses.
9. Remove screws ⑧ and washers ⑨, twelve each, see figure 4. Keep these parts in case fixture has to be shipped back to the factory.
10. Rotate LED cluster back upright and store in safe place. It is possible there will be white thermal paste around the heatsink. This can be cleaned with 70% isopropyl alcohol and q-tips. Warning: Do not use any other solvent for cleaning. Damage may result.
11. Install fixture in desired location (see main installation sheet).
12. As a general rule, fixtures should not be more than 150 feet from data controller. Data wire should be 16 AWG. Actual distances vary according to the number of fixtures connected to the data controller. The maximum length of wire from the data controller to the fixture is 175 feet, including the 10 feet of wire inside the fixture. Example: Two fixtures are connected in series to a data controller. The length of wire from the data controller to the first fixture is 100 feet. The length of wire from the first fixture to the second fixture is 50 feet. Total wire length is $100+10+50+10=170$ feet. This installation is within the requirements.
13. Make sure all power is off. Make data connections inside junction box using waterproof wire-nuts. Data wires are identified as the black and white wires with blue shrink tubing. The white wire is CKDMX and the black wire is DC Ground. All wiring should meet local, state and national electrical codes.
14. Make power connections inside junction box using waterproof wire-nuts. Make sure power circuit is isolated from electrical motors.
15. Place LED cluster on top of housing. Position it so the aiming screws 10 are on the side farthest from the area to be illuminated.
16. Re-connect cables ⑦.
17. Re-install LED cluster into housing.
18. Re-install screws ②.
19. To rotate LEDs loosen screws ⑪, see figure 5. Make necessary adjustment and re-tighten screws. Warning: Check cables ⑦ as adjustments are being made. Cables may need to be repositioned slightly. Make sure cables are clear of fan blades.
20. To tilt LEDs turn aiming screw ⑩. Warning: if using a power screwdriver or drill to turn aiming screw, the clutch must be set on the lowest setting. Do not use power tools without a clutch feature. Damage to the aiming screw will result.

INSTALLATION INSTRUCTIONS, RGB DATA CONTROLLER

1. It is recommended the data controller be installed indoors. However, it may be installed outdoors if it is installed in a waterproof / dustproof enclosure. Suitable enclosures are IP65 rated or NEMA 4, 4X, 6, or 6P rated. Warning: Do not install enclosure on or near the ground. Do not allow enclosure to become submersed in water.
2. As a general rule, the data controller should not be more than 150 feet from the LED fixture. Data wire should be minimum 16 AWG. Actual distances vary according to the number of fixtures connected to the data controller. The maximum length of wire from the data controller to the fixture is 175 feet, including the 10 feet of wire inside the LED fixture. Example: Two fixtures in are connected in series to a data controller. The length of wire from the data controller to the first fixture is 100 feet. The length of wire from the first fixture to the second fixture is 50 feet. Total wire length is $100+10+50+10=170$ feet. This installation is within the requirements.
3. Remove top cover carefully. Some models have components attached to top cover that are wired to components in the housing.
4. Make sure all power is off. Make power connections to the power supply. Connect the brown wire to live, blue wire to neutral, and the green wire to earth ground. All wiring should meet local, state and national electrical codes.
5. On some models, you will need to make data connections. Data wires are identified as the black and white wires with blue shrink tubing. The white wire is CKDMX and the black wire is DC Ground.

P/N 53174

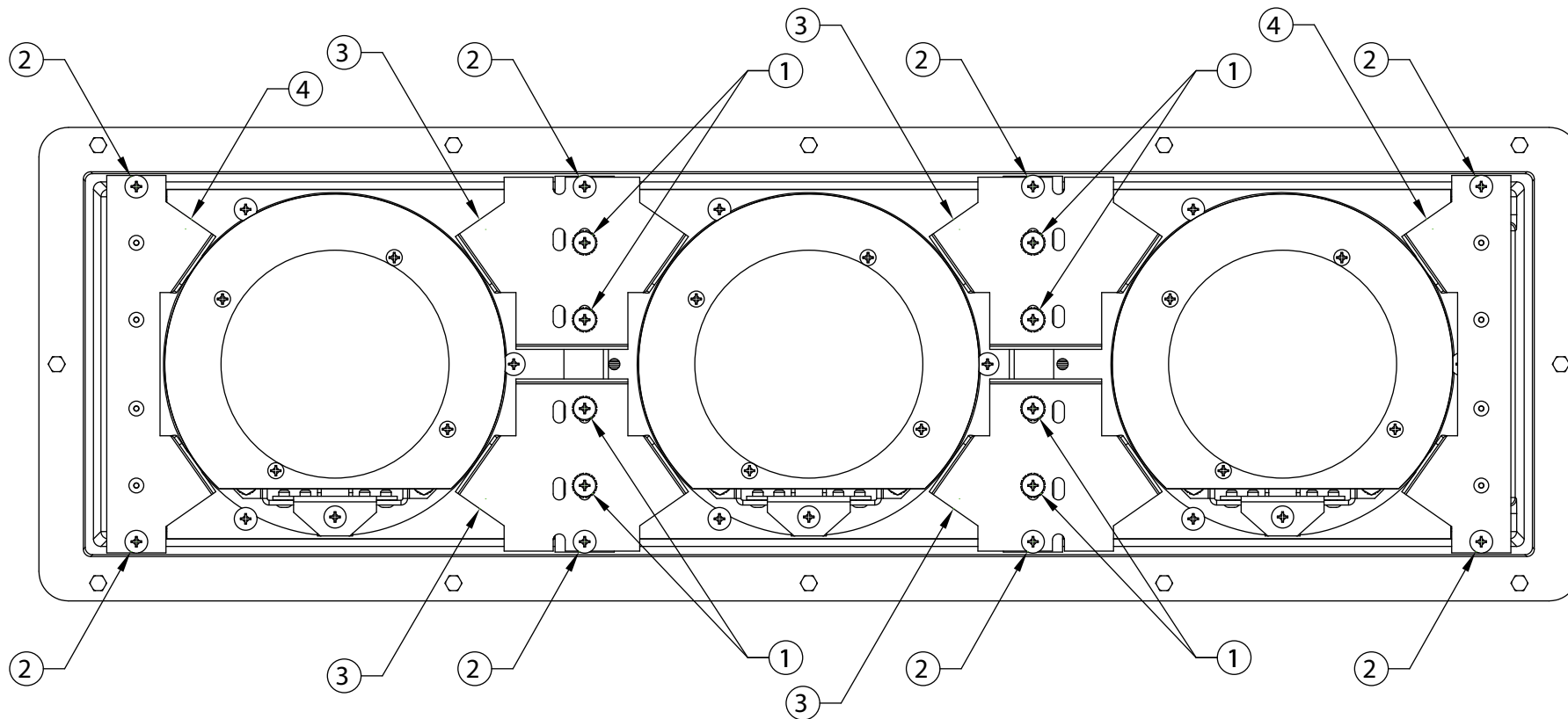

FIGURE 1

AREA TO BE ILLUMINATED

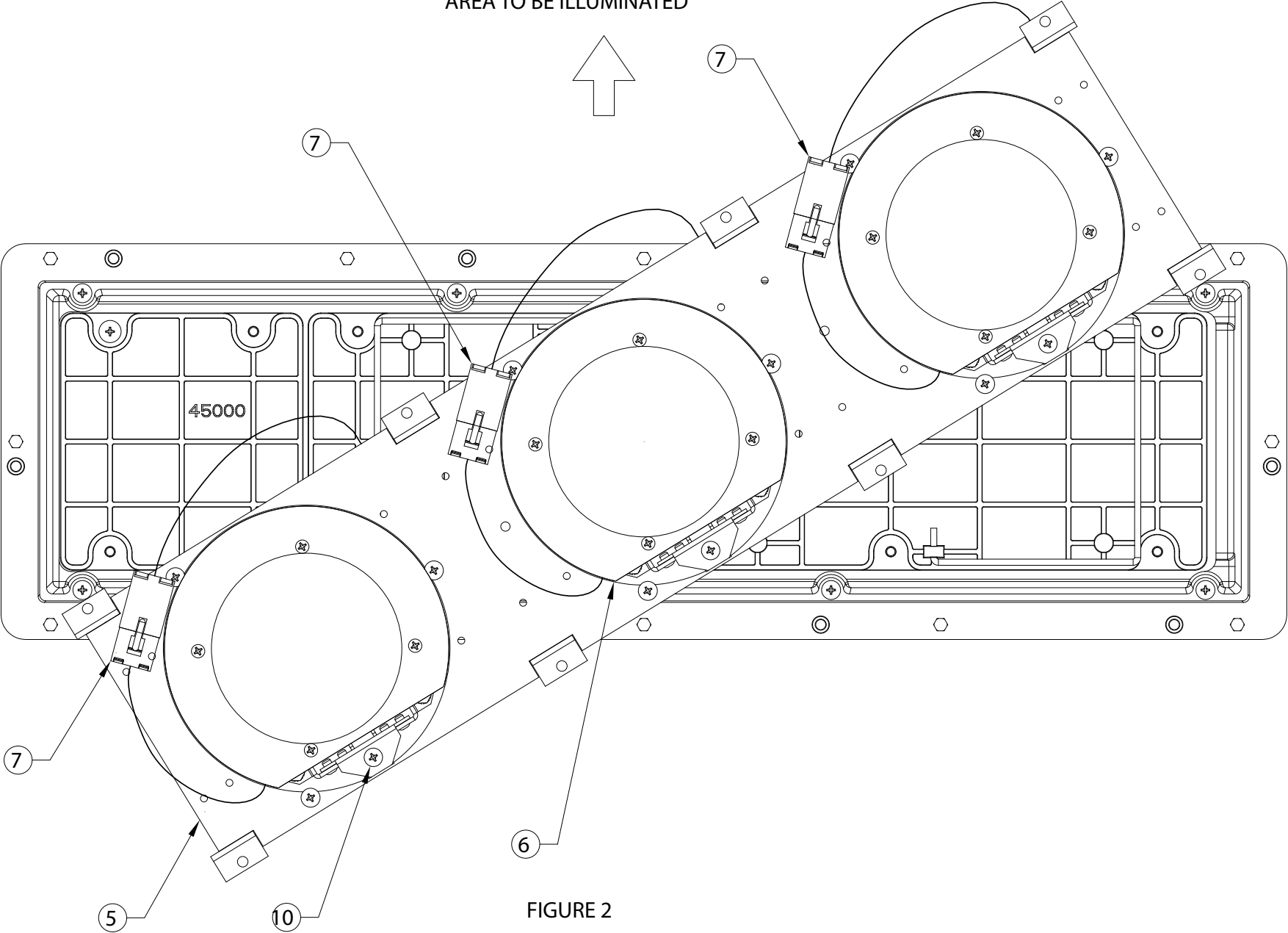
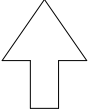

FIGURE 2

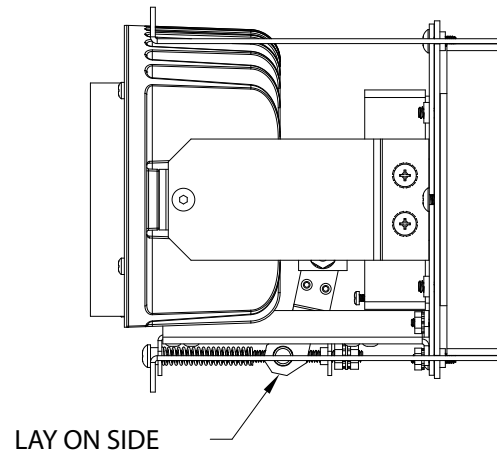

FIGURE 3

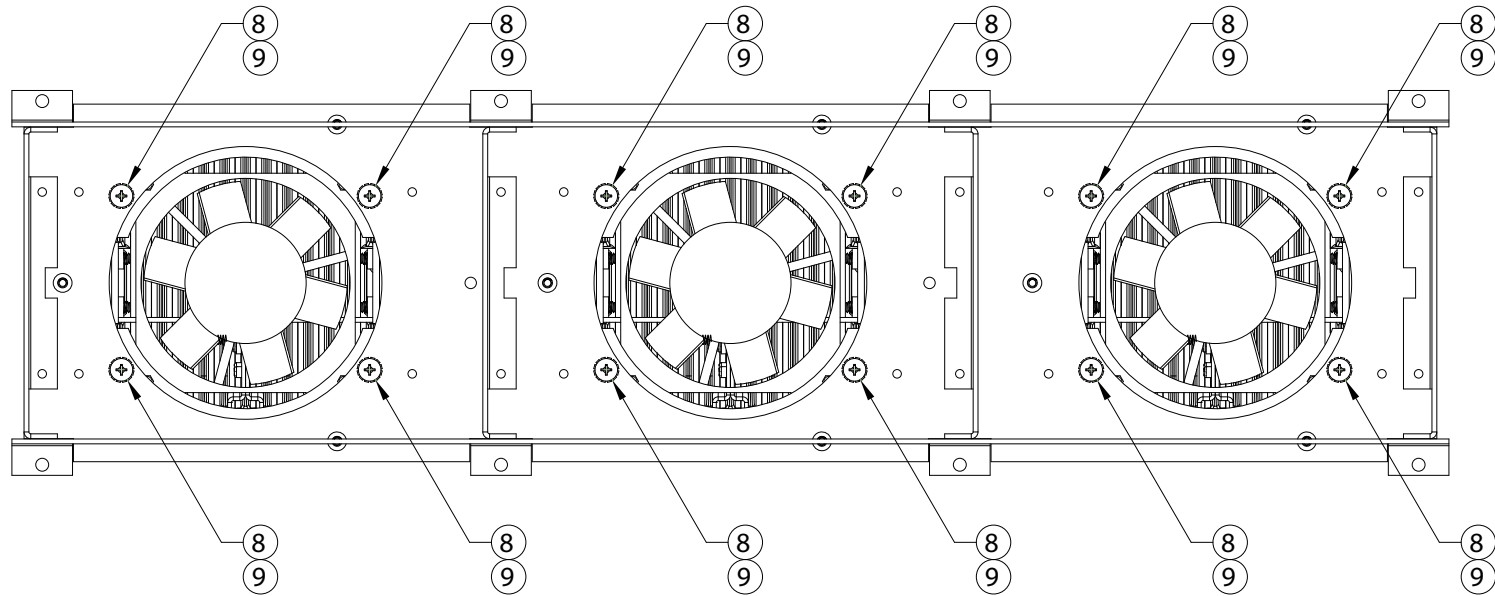
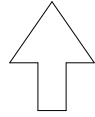

FIGURE 4

P/N 52868

AREA TO BE ILLUMINATED



TURN AIMING SCREW CLOCKWISE

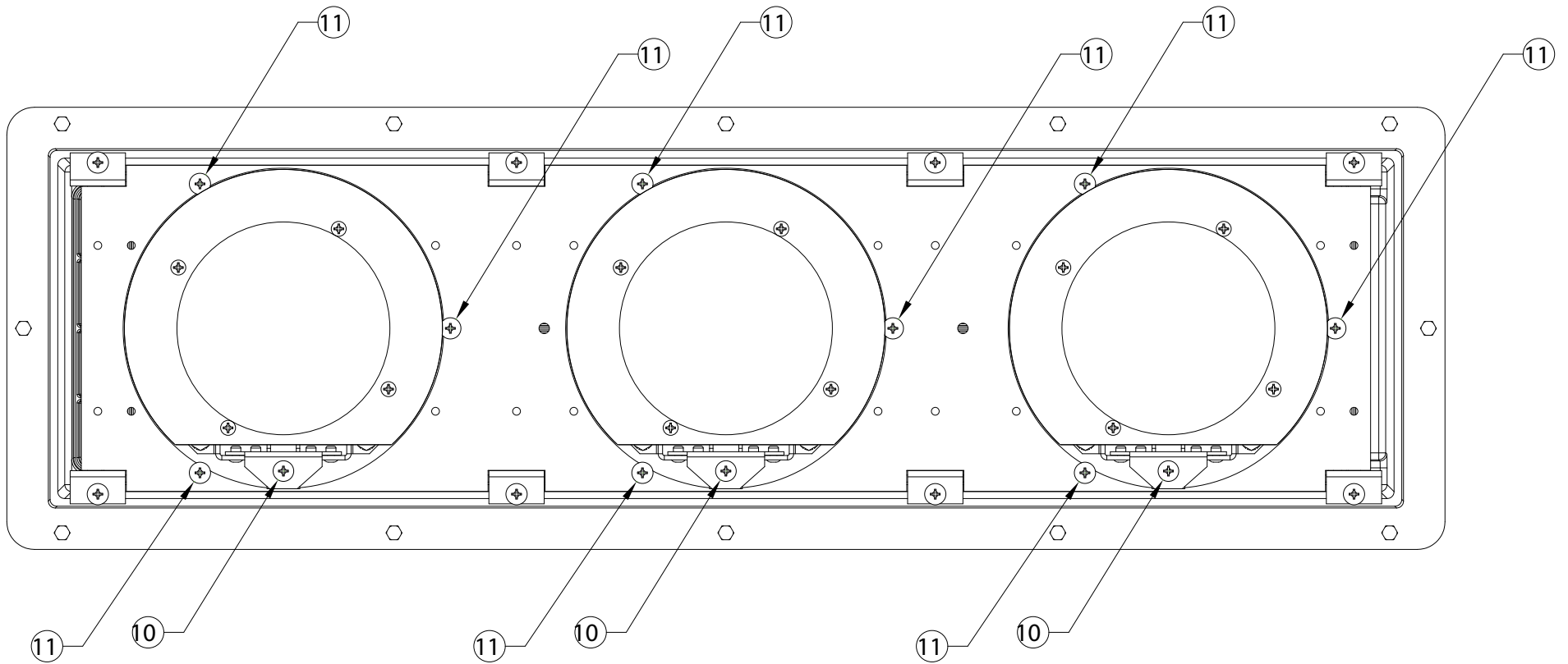

FIGURE 5

SL29LED-RGB BLOCK DIAGRAM

